

Production of
"ERMO - TECHNICAL INSTALLATIONS"
KRATER – Skopje
BULEVAR ILINDEN st.34 No. 1
1041 Skopje
Republic of Macedonia

Tel: +389 2 2552 922
Fax: +389 2 2552 966
e-mail: info@krater.mk
www.krater.mk



Rectangular ducts and fittings catalogue



Rectangular Ducts

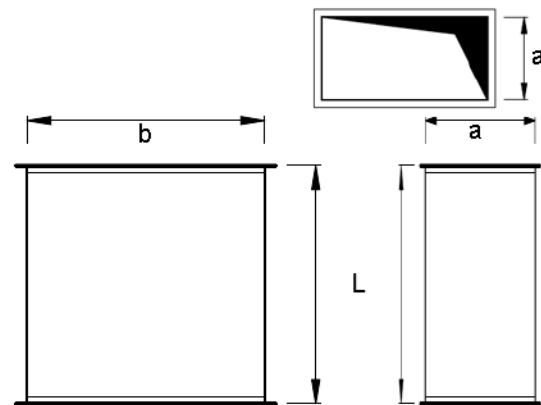
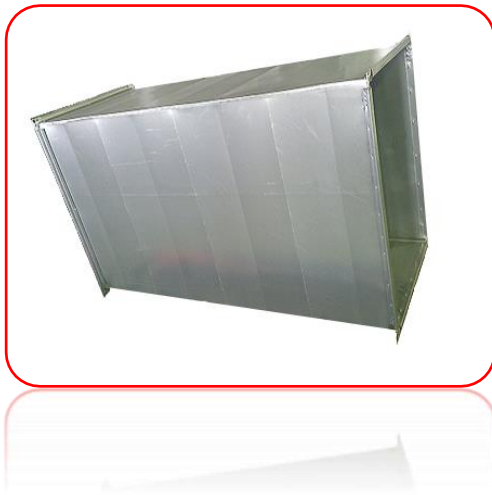

Description

The rectangular ducts are with stiffening for strength improvement. Also according to the dimensions we install galvanized bars to strengthen the duct if it is needed.

We produce rectangular ducts from galvanized steel. Our production line is flexible and we are able to do more than these parts explained here. By normal production and dimensions we give the parts that are more common and demanded. By customers demand we can produce ducts that are not explained in this catalogue. The rectangular ducts are with stiffening for strength improvement. Also according to the dimensions we install galvanized bars to strengthen the duct if it is needed.

Normal dimensions - rectangular ducts

The marking of the normal dimensions are shown on the upper right photo. The normal dimensions are:

- Dimensions **a>150mm** and **b>150mm**.
- Length **L=1500mm**.

Endings

On the ends of the rectangular ducts we install mounting **frames (flanges) 20mm, 30mm and 40mm** in dependence of the dimensions **a** and **b**.

By customer's demand we close one or two ends of the rectangular duct with rectangular cup.

Rectancular bending section

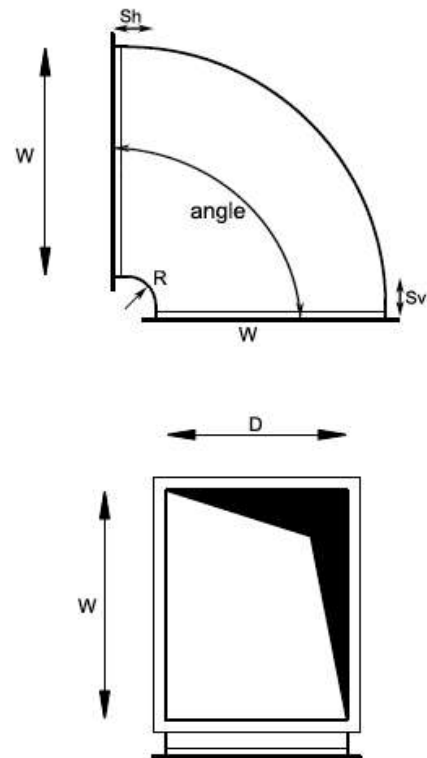
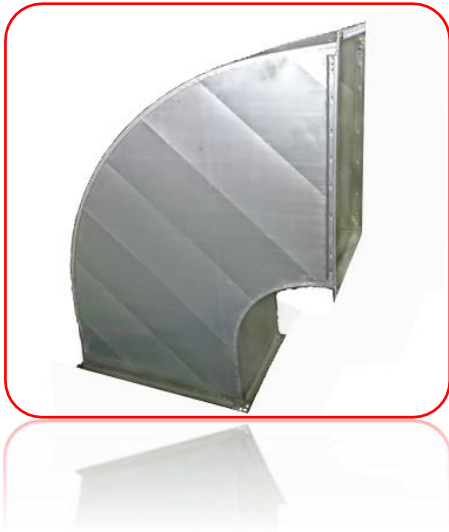

Description

We are characterized with flexible rectangular bend section production.

As shown on the photo all parameters can be modified. The rectangular bend sections are stiffened for strength improvement. According to the dimensions we install galvanized bars and deflectors for better performance and strength if it is needed.

Normal dimensions - rectangular bend section

The dimensions here vary according the parameters shown on the photo. Normal dimensions are considered the most used dimensions. That does not exclude manufacturing dimensions that are not mentioned as normal. The normal dimensions are:

- Dimensions **D>150mm**.
- Any **angle** ($1^\circ < \text{angle} < 180^\circ$)

Endings

On the ends of the Rectancular bending section we install mounting **frames (flanges) and corners** - **20mm, 30mm** and **40mm** in dependence of the dimensions **W** and **D**.

By costumer's demand we close one or two ends of the rectangular duct with rectangular cup.

Rectangular bending types

We are producing different types of bending sections. The most common types are:

- **Bending with equal dimensions on the endings.**

Here are the changeable dimensions:

- Width (bottom) - **W**
- Depth (bottom) - **D**
- Straight part(horizontal) – **Sh**
- Straight part(vertical) – **Sv**
- Radius (internal) - **R**

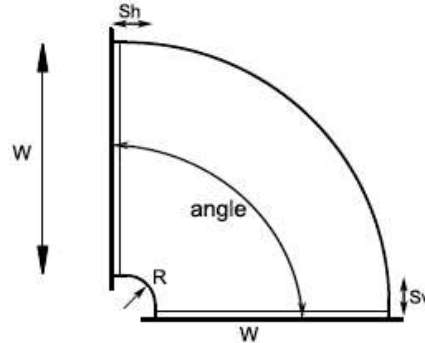

- **Bending with different dimensions on the endings – Reducer bendings**

Here are the changeable dimensions:

- Width (bottom) - **Wb**
- Depth (bottom) - **Db**
- Width (top) - **Wt**
- Depth (top) - **Dt**
- straight part top
- straight part down
- Straight part(horizontal) - **Sh**
- Straight part(vertical) - **Sv**

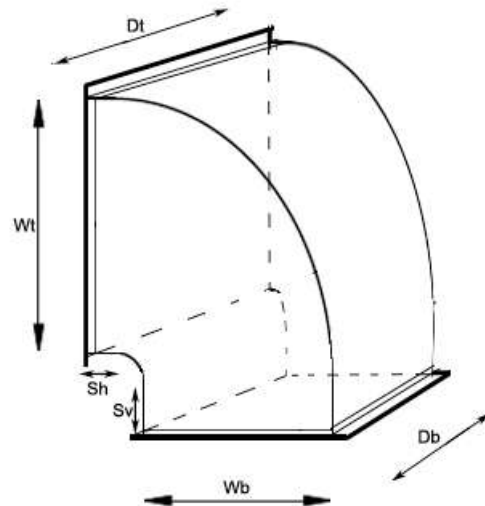

- **Reducer bending by different angle and different a, b, c, and d dimensions**

Here all the parameters are changeable:

- Width (bottom) - **Wb**
- Depth (bottom) - **Db**
- Width (top) - **Wt**
- Depth (top) - **Dt**
- Radius (internal) - **Ri**
- Angle - **angle**
- Straight part(bottom) - **Sb**
- Straight part(top) - **St**

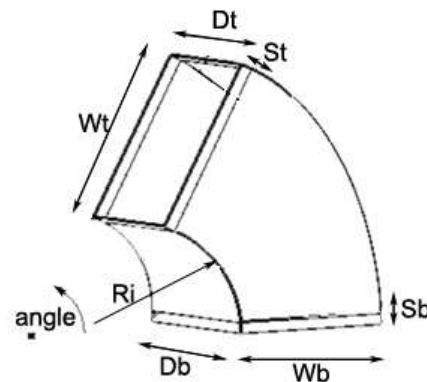

• **Rectangular bending with two different angles.**

On this element we can change these parameters:

- Width (top) – a
- Depth – b
- Width (bottom) – c
- Radius (internal) – Ri
- Radius (external) – Re
- Angle (top) – angle2
- Angle (bottom) – angle1
- Straight part (horizontal) – Sh
- Straight part (vertical) - Sv

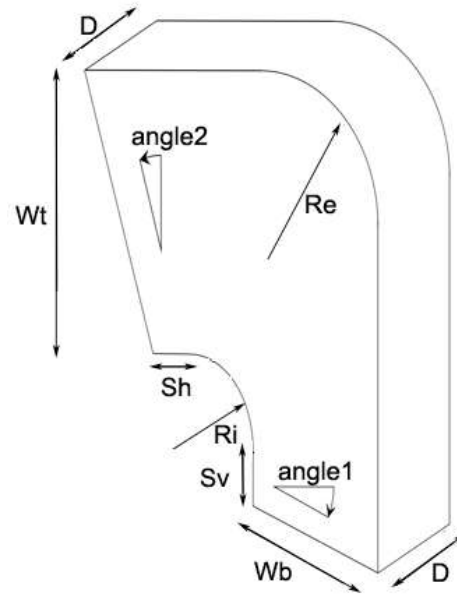

• **Rectangular bending sections with splitters.**

On this bending we can change these parameters:

- Width top – Wt
- Width bottom – Wb
- Depth – D
- Radius (internal) – Ri
- Distance – W/8
- Distance – W/3
- Distance – W/2

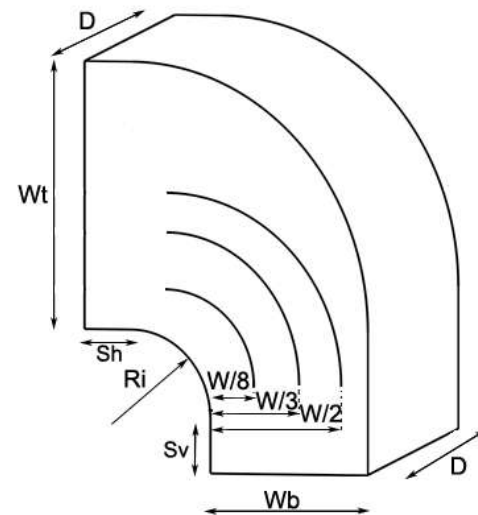

The rectangular bending sections with splitters are produced according the next regulative:

Width -W (mm)	No. of Splitters	Splitter placing (mm)		
		W/3	/	/
400 to 800	1	W/3	/	/
801 to 1600	2	W/4	W/2	/
1601 to 2000	3	W/8	W/3	W/2

The system used for installing the splitters is composed of guiding clips that hold the splitter and special conical ending. Those are shown together with their use.

Guiding clips

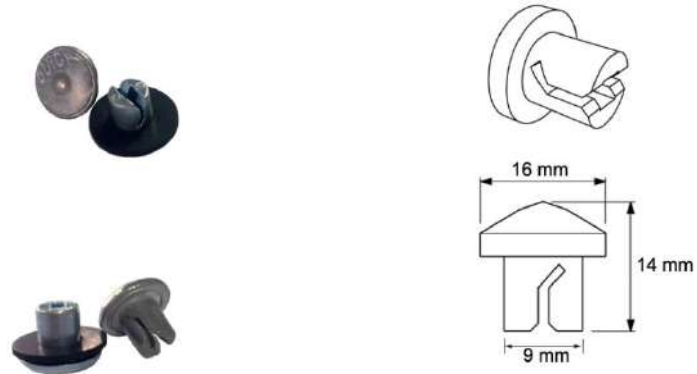

Conical ending

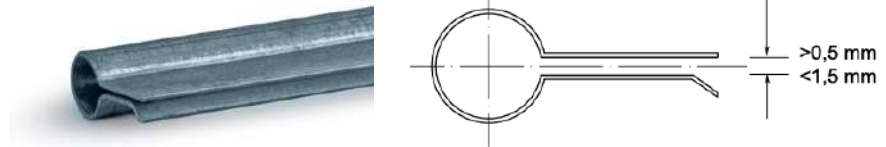

Installing splitters

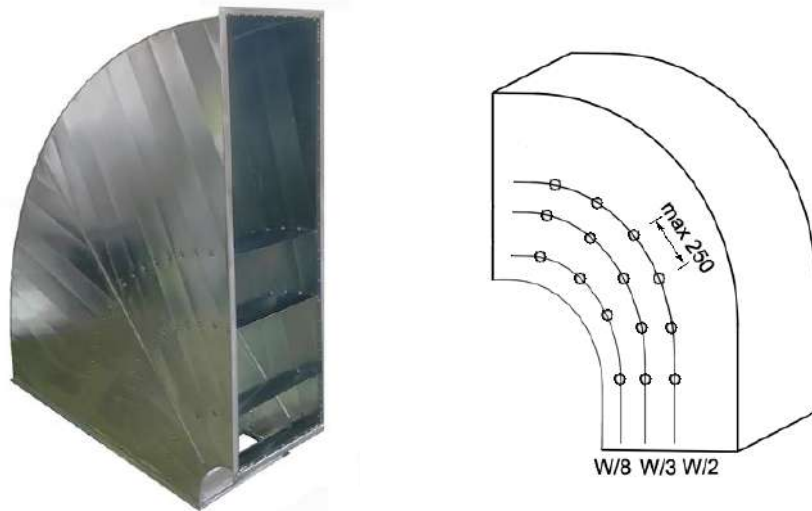

One side rectangular reducer

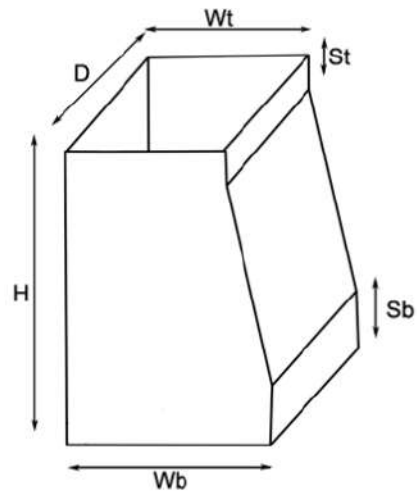

Description

The one side rectangular reduction sections – reducers, are one of the basic parts used for HVAC ventilations. On this type of a reducer the adjustable parameters are shown and explained bellow.

Normal dimensions - rectangular reduction sections – reducers

The dimensions here vary according the parameters shown on the photo. Normal dimensions are considered the most used dimensions. That does not exclude parts from manufacturing which dimensions are not mentioned as normal. The normal dimensions are:

- Dimensions **D > 150mm**.
- Straight parts **St** (straight part top) and **Sb** (straight part bottom) = **30 mm**
- Any Height **H > 150**
- Any Width-top **Wt > 150mm**.
- Any Width-bottom **Wb > 150mm**.

Endings

On the ends of the One side rectangular reducer we install mounting **frames (flanges) and corners** - **20mm, 30mm and 40mm** in dependence of the dimensions **Wt, Wb** and **D**.

Both sides rectangular reducer

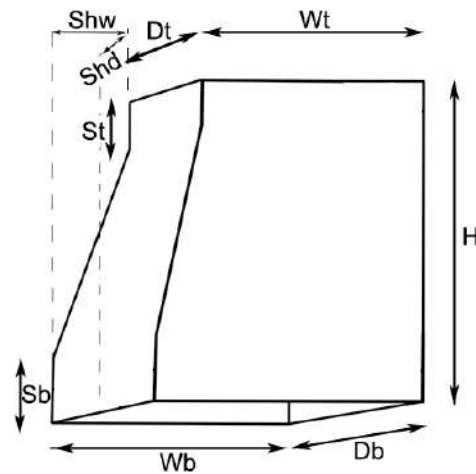
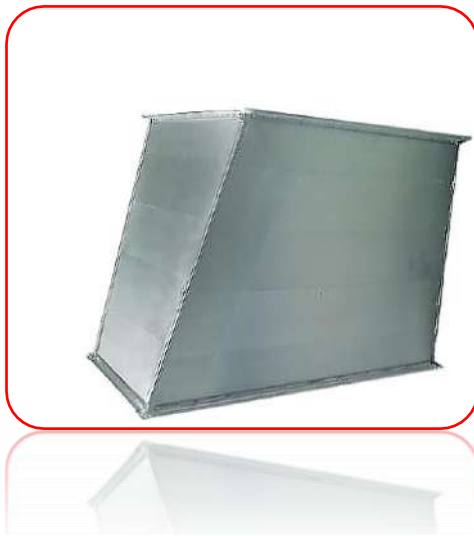

Description

Both side rectangular reduction sections – reducers, can be designed in variable situations. They are flexible and can be designed to accomplish the customer's demands. The adjustable parameters of the both side reducer sections are shown and explained below.

Normal dimensions – both sides rectangular reduction sections – reducers

Normal dimensions are considered the most used dimensions. That does not exclude parts from manufacturing which dimensions are not mentioned as normal. The normal dimensions are:

- **Dt** (depth top) and **Db** (depth bottom) >150mm.
- Straight parts **St** (straight part top) and **Sb** (straight part bottom) = 30 mm
- Any Height **H**>150
- Any Width-top **Wt**>150mm.
- Any Width-bottom **Wb**>150mm.
- Shift width **Shw**
- Shift depth **Shd**

On the ends of the Both side rectangular reduction sections we install mounting **frames (flanges) and corners** - 20mm, 30mm and 40mm in dependence of the dimensions **Wt, Wb, Dt** and **Db**.

Depending of the adjustable parameters, mostly by changing Shift width - **Shw** and Shift depth – **Shd**, we can separate **two basic types of both side rectangular reduction sections**:

- **Eccentric both side rectangular reduction sections.**

On this type of reduction section the shifting is done in a way so it is shifted asymmetrical to the center axes.

This type has the following parameters:

- | | |
|--|---|
| - Wb - Width (bottom) | - Wt - Width (top) |
| - Db - Depth (bottom) | - Dt - Depth (top) |
| - Shd - Shift (depth) | - Shw - Shift (width) |
| - Sb (30 mm) - Strait part (bottom) | - St (30 mm) - Strait part (top) |

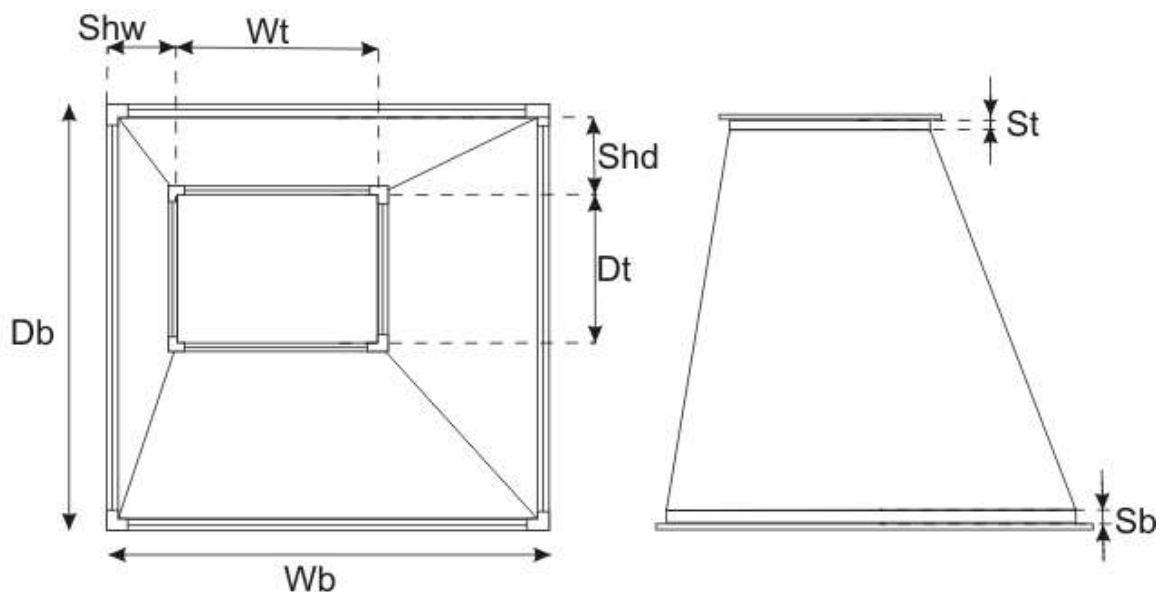

Endings

On the ends of Eccentric both side rectangular reduction sections we install mounting **frames (flanges) and corners - 20mm, 30mm and 40mm** in dependence of the dimensions **Wt, Wb, Dt** and **Db**.

- **Concentric both side rectangular reduction sections.**

On this type of reduction section the shifting is done in a way so it is shifted symmetrical to the center axes. This type has the following parameters:

- **Wb** - Width (bottom)
- **Db** - Depth (bottom)
- **Shd** - Shift (depth)
- **Sb** (30 mm) - Strait part (bottom)
- **Wt** - Width (top)
- **Dt** - Depth (top)
- **Shw** - Shift (width)
- **St** (30 mm) - Strait part (top)

Recommendations:

$$\text{Shift (depth)} \mathbf{Shd} = \frac{[\text{depth(bottom)} \mathbf{Db} - \text{depth(top)} \mathbf{Dt}]}{2}$$

$$\text{Shift (width)} \mathbf{Shw} = \frac{[\text{width(bottom)} \mathbf{Wb} - \text{width(top)} \mathbf{Dt}]}{2}$$

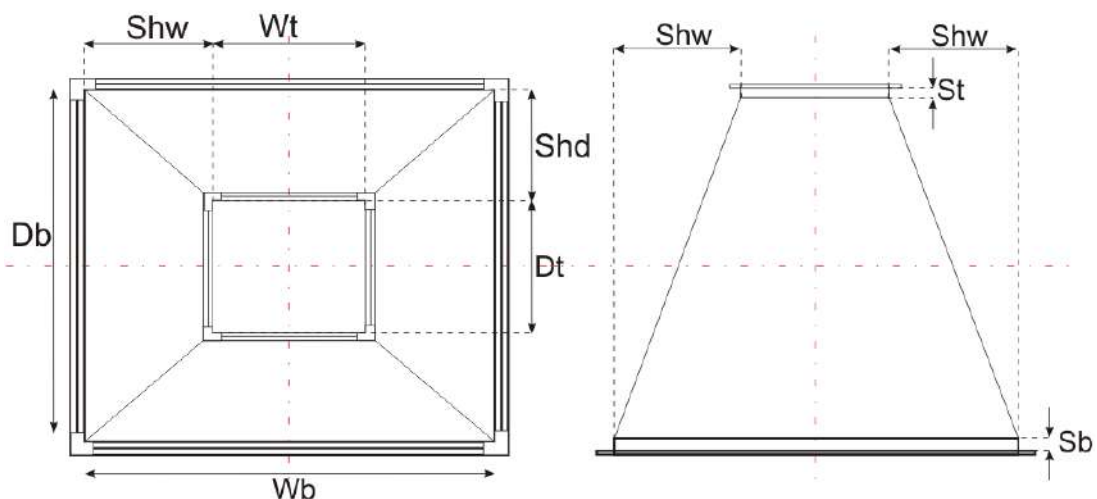

Endings

On the ends of the rectangular reduction sections we install mounting **frames (flanges) and corners** - 20mm, 30mm and 40mm in dependence of the dimensions **Wt, Wb, Dt** and **Db**.

Rectangular shift section – setoff

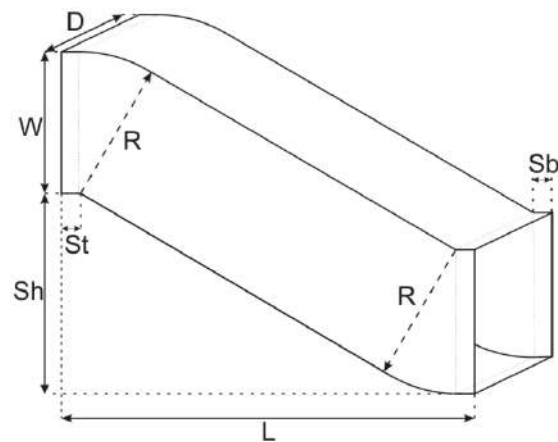

The rectangular sift section – setoff has the following adjustable parameters:

- **W >150mm** - Width
- **D >150mm** - Depth
- **Sh *** - Shift
- **St** (30 mm) - Strait part (top)
- **Sb** (30 mm) - Strait part (bottom)
- **L *** - Length

Description

The **rectangular shift section - setoff** is one of the standard and often used types rectangular ducting sections. It can help to shift the duct line in any direction.

There are some basic recommendation that should be considered during planning this elements, that are not an obligation:

*Recommendations:

$$\text{Shift } Sh < \frac{\text{Length } L}{2}$$

$$\text{Length } L = \frac{3 * W}{2} = 1,5 * W$$

$$\text{Radius } R = \text{Width } W$$

Endings

On the ends of **rectangular shift section - setoff** we install mounting **frames (flanges) and corners** - **20mm, 30mm** and **40mm** in dependence of the dimensions **W** and **D**.



Rectangular cross section setoff with variable endings

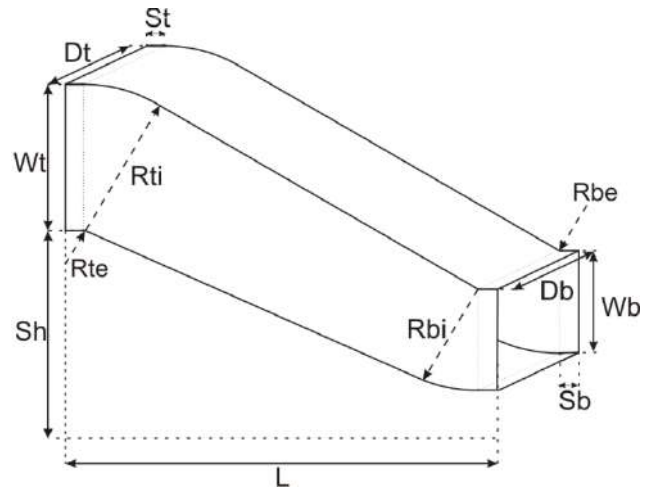
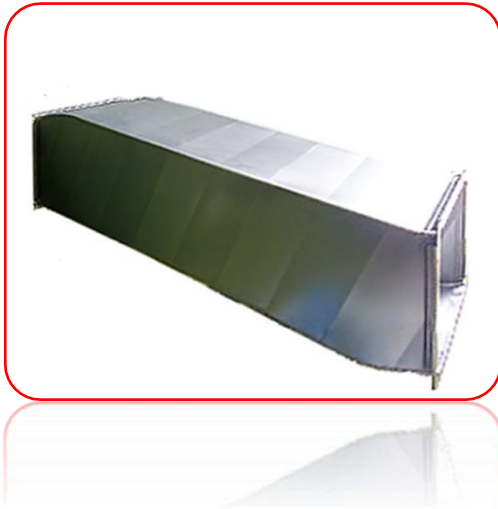

The rectangular cross section setoff has the following adjustable parameters:

- **Wb** - Width (bottom)
- **Db** - Depth (bottom)
- **Sb** (30 mm) - Strait part (bottom)
- **Rbi** - Radius (bottom internal)
- **Rbe** - Radius (bottom external)
- **Sh*** - Shift
- **Wt** - Width (top)
- **Dt** - Depth (top)
- **St** (30 mm) - Strait part (top)
- **Rti** - Radius (top internal)
- **Rte** - Radius (top external)
- **L*** - Length

Description

The rectangular cross section setoff is another one of the standard and often used types rectangular ducting sections. It can help to shift the duct line in any direction and change it's dimensions.

There are some basic recommendations that should be considered during planning this elements, that are not an obligation:

** Recommendations:*

$$Shift \mathbf{Sh} < \frac{Length \mathbf{L}}{2}$$

$$Length \mathbf{L} > \frac{3 * \mathbf{W}}{2} = 1,5 * \mathbf{W}$$

Endings

On the ends of rectangular shift section - setoff we install mounting frames (flanges) and corners - 20mm, 30mm and 40mm in dependence of the dimensions **Wb,Wt.Db** and **Dt**.

Concentric rectangular to round reducers

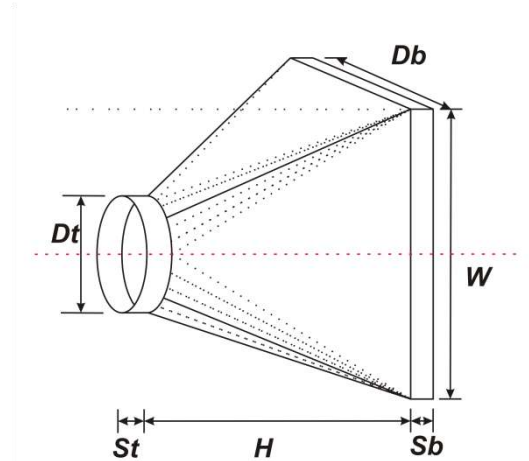
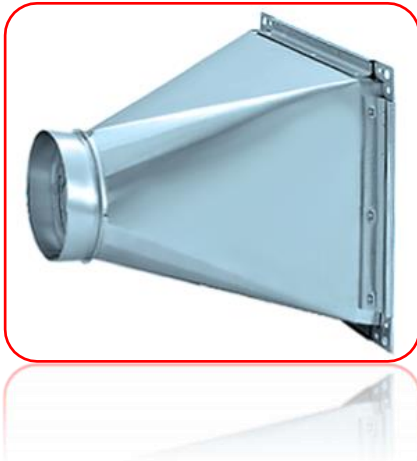

The **concentric rectangular to round reducers** has the following adjustable parameters:

- **W** - Width
- **D** - Depth
- **Sb** (30 mm) - Strait part (bottom)
- **Sh** – Shift ($Sh_w = 0, Sh_b = 0$)
- **Dt** – Diameter (top)
- **St** - (30 mm) - Strait part (top)
- **H** – Length

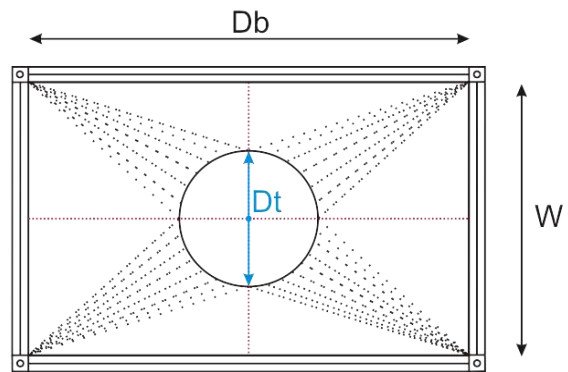

Description

The **concentric rectangular to round reducers** are used to change from circular to rectangular duct line and as a connection and fitting for various elements.

Endings

On the one end of **concentric rectangular to round reducers** we install mounting **frames (flanges) and corners** - 20mm, 30mm and 40mm in dependence of the dimensions **W** and **Db**. On the other end there is a coupling for connecting the circular element or circular flange.

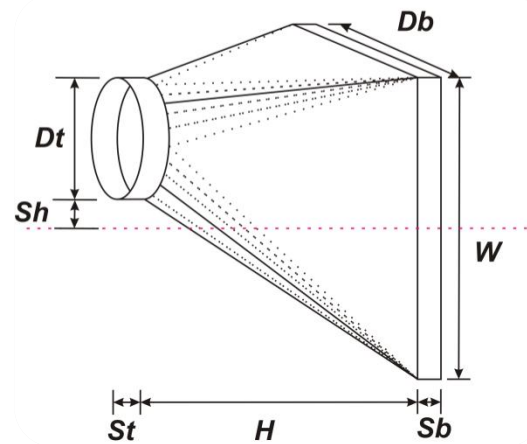
Eccentric rectangular to round reducers

The eccentric rectangular to round reducers has the following adjustable parameters:

- **W** - Width
- **Db** - Depth
- **Sb** (30 mm) - Strait part (bottom)
- **Shd** – Shift depth
- **Dt** – Diameter (top)
- **St** - (30 mm) - Strait part (top)
- **H** – Length
- **Shw** – Shift width

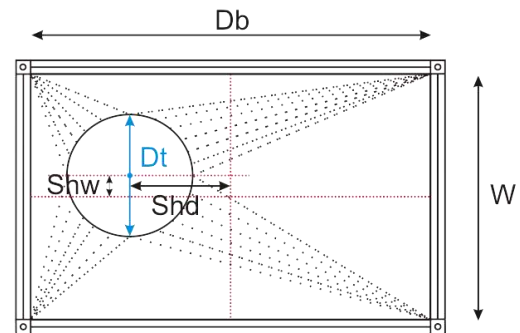

Description

The **eccentric rectangular to round reducers** are used to change from circular to rectangular duct line and as a connection and fitting for various elements.

Endings

On the one end of **eccentric rectangular to round reducers** we install mounting **frames (flanges) and corners - 20mm, 30mm and 40mm** in dependence of the dimensions **W** and **Db**. On the other end there is a coupling for connecting the circular element or circular flange.

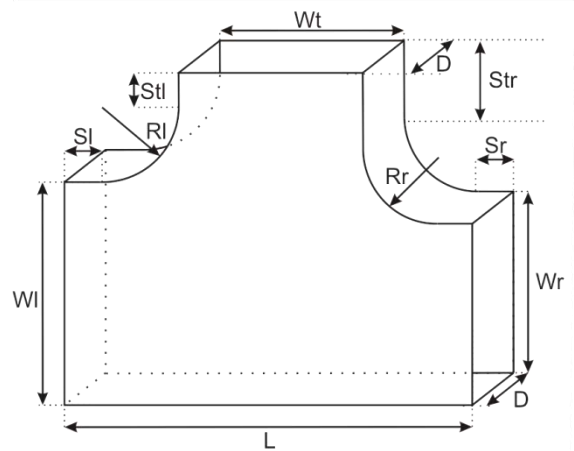
3-Way rectangular Tees - "T-piece"



The **3-way rectangular T-section** has the following adjustable parameters:

- **Wl** - Width (left)
- **Sl** (30 mm) - Strait part (left)
- **Rl** - Radius (left)
- **Stl** – Strait part (top left)
- **D** - Depth
- **Wt** – Width (top)
- **Wr** - Width (right)
- **Sr** (30 mm) - Strait part (right)
- **Rr** - Radius (right)
- **Str** – Strait part (top right)
- **L*** – Length

Description

The **3-way rectangular T-section** are used to split one duct line to two duct lines or connect two duct lines into one duct line. With different values of the parameters the T-section has different shapes.

Endings

On the one end of **3-way rectangular T-section** we install mounting **frames (flanges) and corners** - **20mm, 30mm and 40mm** in dependence of the dimensions **Wl,Wr,Wt** and **D**.

3-way rectangular section with a single side part

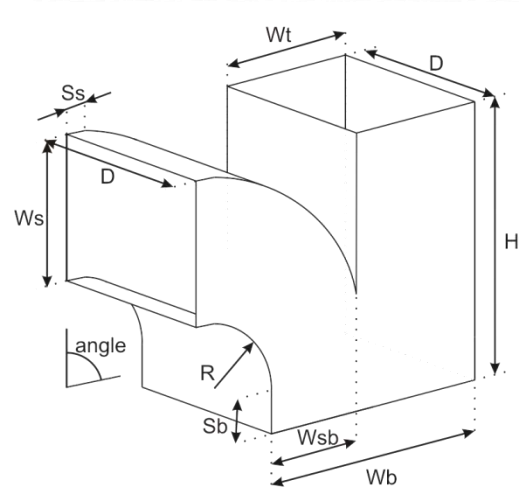

The **3-way rectangular section with a single side part** has the following adjustable parameters:

- **Wb** - Width (bottom)
- **Sb** (30 mm) - Strait part (bottom)
- **R** - Radius
- **D** - Depth
- **Wt** - Width (top)
- **Ws** - Width (side)
- **Wsb** - Width (side bottom)
- **angle**
- **Ss** - Strait part (side)
- **H** - Height

Description

The **3-way rectangular section with a single side part** are used to split one duct line to two duct lines or connect two duct lines into one duct line. With different values of the parameters the 3-way rectangular section has different shapes.

Endings

On the one end of **3-way rectangular T-section** we install mounting **frames (flanges) and corners** - 20mm, 30mm and 40mm in dependence of the dimensions **Wb, Wsb, Ws, Wt** and **D**.

Double rectangular-section with 2 different side parts

Y - section -

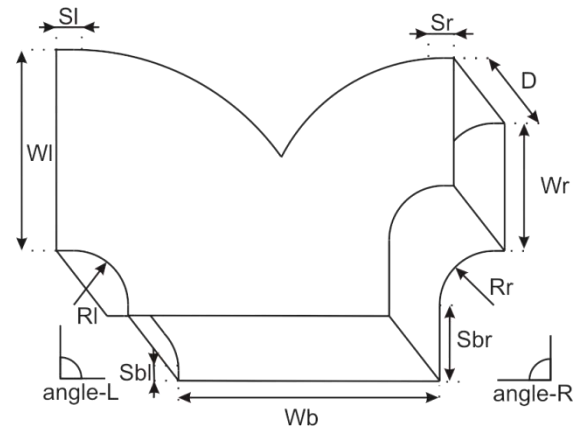

The **Double rectangular-section with 2 different side parts - Y - section** has the following adjustable parameters:

- **Wb** - Width (bottom)
- **Sbr** (30 mm) - Strait part (bottom right)
- **Rr** - Radius (right)
- **Wr** - Width (right)
- **angle-R** - (right)
- **Sr** - Strait part (right)
- **D** - Depth
- **Sbl** (30 mm) - Strait part (bottom left)
- **Rl** - Radius (left)
- **Wl** - Width (left)
- **angle-L** - (left)
- **Sl** - Strait part (left)

Description

The **rectangular-section with 2 different side parts - Y - section** are used to split one duct line to two duct lines or connect two duct lines into one duct line. With different values of the parameters the 3-way rectangular section has different shapes.

Endings

On the one end of **3-way rectangular T-section** we install mounting **frames (flanges) and corners** - **20mm, 30mm** and **40mm** in dependence of the dimensions **Wb,Wr,Wl** and **D**.

Additions:

The elements and sections explained in the upper chapters are most common used elements. We have a lot of different elements that are not described in this catalogue.

Frames

On the endings on the ducts and on the segments we are installing a mounting frames of different dimensions. We are installing mounting frames 20mm from flange 20mm and 20 mm corners on sections <1000mm. On sections above 1000mm and less then 2000mm we install mounting frames with flange 30mm and corners 30mm. On ducts and sections larger then 2000mm we install 40mm mounting frames with suitable corners 40mm.

Stiffening and strengthening

All the elements produced in our manufacturing facility are adequate stiffened and strengthened to sustain the necessary pressure class demanded by our costumer. We use different type of steel bars and baffles installed into the ducts and sections so their strength is insured. They are carefully and professionally installed into the duct.

Insulation

On the ducts and sections and special elements we also install different types of insulation depending of the use of that duct line, and the needs of our costumer. The insulations can be from various types and dimensions (thickness). Insulation can be different material and combination of material, external or Internal, etc.

Flanges

We also produce flanges from galvanized and stainless steel. We are making them with different dimensions and thickness according our costumer's needs.

Balancing tape

We also install balancing tape on costumer's demand. The balancing tape is installed and mounted on the right element if it is demanded. It is necessary to install a balancing tape if there is a need to stop the spreading of the noise trough the duct line.

Dumper mechanism

The dumper mechanism is made from galvanized sheet metal. We install the dumper mechanism if it is agreed with the costumer on the right section of the duct line.

Following this additions chapter there are some photos that will show some of our products:



- *Plenum boxes – various types*



- *Rectangular to round diffusers*



- *Round Ducts and T-sections*



- *Couplings*

